

ISSUES

No.	DESCRIPTION	DATE
1	ISSUED FOR RE-ZONING/OPA	2020-08-31

PROPOSED PARKING BLDG. A

Level	Count
SURFACE PARKING	41
LEVEL 1 GROUND FLOOR	5
LEVEL P1	81
A-R	127
SURFACE PARKING	26
A-V	26
TOTAL	153

BUILDING A (127 UNITS) :
127 RESIDENTIAL @ PROPOSED RATIO: 1.0 / UNIT
26 VISITORS @ PROPOSED RATIO: 0.2 / UNIT

PROPOSED PARKING BLDG. B

Level	Count
SURFACE PARKING	42
LEVEL 1 GROUND FLOOR	6
LEVEL P1	78
B-R	126
SURFACE PARKING	25
B-V	25
TOTAL	151

BUILDING B (126 UNITS) :
126 RESIDENTIAL @ PROPOSED RATIO: 1.0 / UNIT
25 VISITORS @ PROPOSED RATIO: 0.2 / UNIT

PROPOSED PARKING BLDG. C

Level	Count
LEVEL 04	66
LEVEL 03	67
LEVEL 02	67
LEVEL 1 GROUND FLOOR	50
C-R	250
SURFACE PARKING	50
C-V	50
TOTAL	300

BUILDING C (250 UNITS) :
250 RESIDENTIAL @ PROPOSED RATIO: 1.0 / UNIT
50 VISITORS @ PROPOSED RATIO: 0.2 / UNIT

PROPOSED PARKING TOTAL BY LEVEL

Level	Count
LEVEL 04	66
LEVEL 03	67
LEVEL 02	67
SURFACE PARKING	184
LEVEL 1 GROUND FLOOR	61
LEVEL P1	159
TOTAL: 604	604

SITE TOTAL (603 UNITS)
503 RESIDENTIAL @ PROPOSED RATIO: 1.0 / UNIT
101 VISITORS @ PROPOSED RATIO: 0.2 / UNIT
SITE TOTAL PARKING SPACES : 604

LEGEND - PARKING SPACE DIMENSIONS

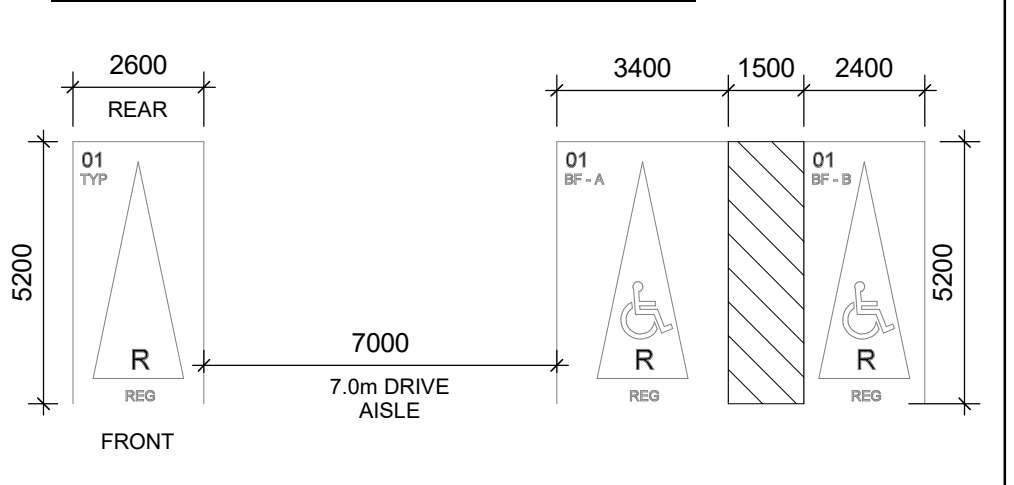

* 0.1m INCREASE ON EACH SIDE WITH OBSTRUCTION MORE THAN 1.0m FROM THE FRONT OR REAR OF THE PARKING SPACE

TYPICAL PARKING SPACE SIZE
5.2m LENGTH / 2.6m WIDTH / 2.0m VERTICAL CLEARANCE

ACCESSIBLE PARKING SPACE

TYPE A
5.2m LENGTH
3.4m WIDTH - ADJACENT TO A 1.5m ACCESS AISLE
2.1m VERTICAL CLEARANCE

TYPE B
5.2m LENGTH
2.4m WIDTH - ADJACENT TO A 1.5m ACCESS AISLE
2.1m VERTICAL CLEARANCE

LEGEND - PARKING SYMBOLS & NOTATIONS

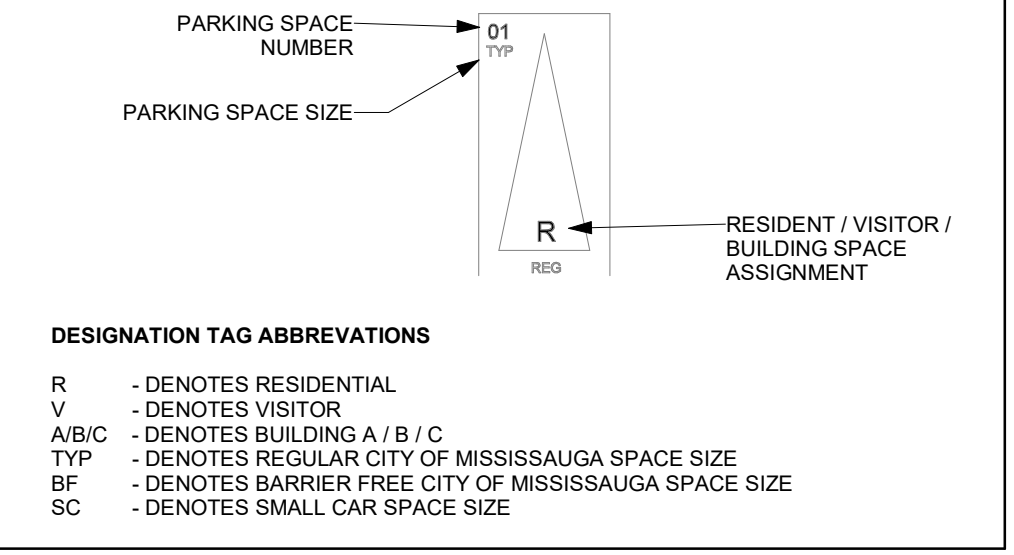

TOTAL RESIDENTIAL BIKE SPACES

Level	Total Bike Spaces	RES LT	RES ST
LEVEL P1	121	121	0
LEVEL 1 GROUND FLOOR	60	20	40
LEVEL 02	15	15	0
LEVEL 03	15	15	0
LEVEL 04	5	5	0
TOTAL BIKE SPACES	216	176	40

BUILDING C (250 UNITS)
176 LONG TERM BIKE @ REQUIRED RATIO: 0.7 / UNIT
20 SHORT TERM BIKE @ REQUIRED RATIO: 0.08 / UNIT

BUILDING A+B (253 UNITS)
20 SHORT TERM BIKE @ REQUIRED RATIO: 0.08 / UNIT

IBI GROUP
95 St. Clair Avenue West, 7th Floor
Toronto, ON M5V 2Y7, Canada
Tel: 416 596 1300 / Fax: 416 596 0644
ibigroup.com

PROJECT
ARGYLE
2570 - 2590 Argyle Rd.
CITY OF MISSISSAUGA, ON
PART OF BLOCK A
REGISTERED PLAN E - 23

PROJECT NO: 120325
DRAWN BY: [] **CHECKED BY:** []
PROJECT MGR: [] **APPROVED BY:** []

SHEET TITLE
UNDERGROUND GARAGE
PLAN - LEVEL P1

SHEET NUMBER A101 **ISSUE** 1

