

This drawing is an instrument of service, it is provided by and is the property of Turner Fleischer Architects Inc. The contractor must verify and accept responsibility for all dimensions and conditions on site and must notify Turner Fleischer Architects Inc. of any variations from the supplied information. This drawing is not to be scaled. The architect is not responsible for the accuracy of survey, structural, mechanical, electrical, etc. information shown on this drawing. Refer to the appropriate consultant drawings before proceeding with the work. Construction must conform to all applicable codes and requirements of all relevant taxing jurisdictions. The contractor working from drawings not specifically marked for construction must assume full responsibility and bear costs for any corrections or damages resulting from his work.

### TYPICAL PARKING DIMENSIONS:

aisle width: MIN 7m

TYPICAL PARKING SPACE:  
MIN 2.6 x 5.2 x 2.0m HIGH

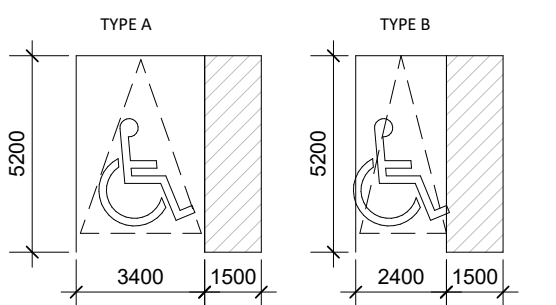
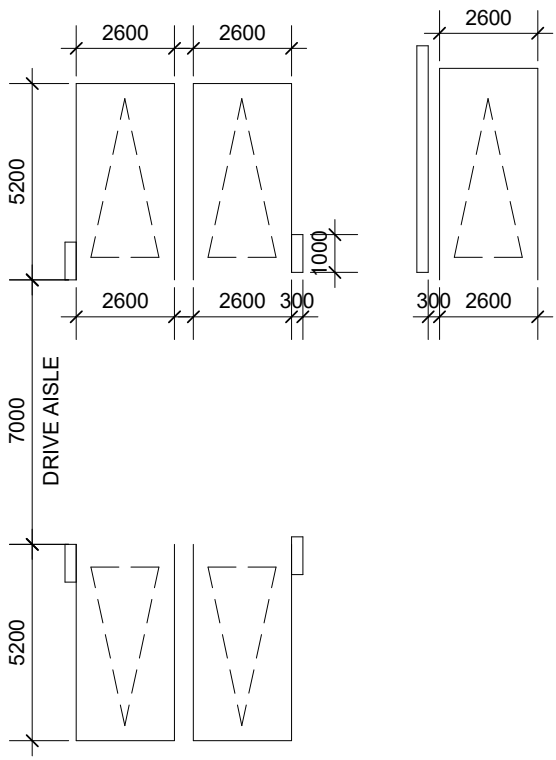

### LEGEND

WALL/COLUMN-MOUNTED CONVEX MIRRORS

V VISITOR PARKING

The minimum width of a parking space, other than an accessible parking space or parallel parking space, shall be increased to 2.75 m where the length of one side of the parking space abuts a building, structure or part thereof, except for a building, structure or part thereof, that extends 1.0 m or less into the front and/or rear of the parking space.



#	DATE	DESCRIPTION	BY
1	2020-06-16	ISSUED FOR REZONING	DV

PROJECT  
**18.150FS**  
420 LAKESHORE ROAD E, MISSISSAUGA, ON

DRAWING  
**UNDERGROUND LEVEL 01**

PROJECT NO. 18.150FS	<p>ONTIARIO ASSOCIATION of ARCHITECTS STEVEN D. NOMS LICENCE 6562</p>
PROJECT DATE 2020-06-16	
DRAWN BY DV	
CHECKED BY RMM	
SCALE As indicated	

DRAWING NO.  
**RZ103**